

**Power line filters for three- phase systems**  
**Rated voltage 440/250 Vac, 50/60 Hz**  
**Rated current 8 A to 1600 A**

**Construction**

- Three- line filter
- Metal case

**Features**

- Very high insertion loss
- Low leakage current
- Easy to install
- Space- saving construction
- Construction complies with UL 1283, CSA 22.2 No.8 1986
- Optimized for long motor cables and operation under full load

**Applications**

- Frequency converters for motor drives, e.g.
  - lifts
  - pumps
  - traction systems
  - conveyor systems
  - air conditioning systems
- Wind- driven power plants
- Power supplies

**Terminals**

- Safe- to- touch terminal blocks for filters up to 180 A
- Terminal lugs for filters 250 to 1600 A



**Typical circuit diagram**

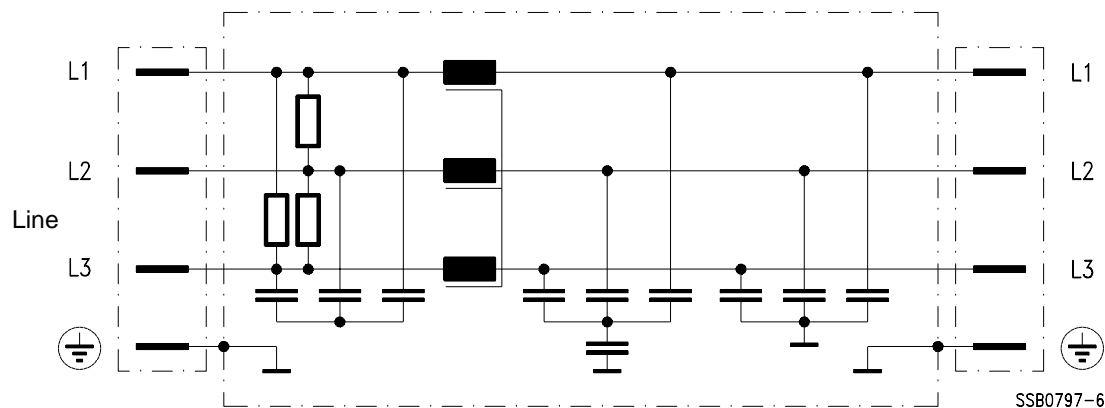

**Technical data**

Rated voltage $V_R$	440/250 Vac, 50/60 Hz
Rated current $I_R$	Referred to 40 °C ambient temperature
Test voltage $V_P$	2121 Vdc, 2 s (line/line) 2700 Vdc, 2 s (lines/case), for 8 ... 180 A 2121 Vdc, 2 s (lines/case), for 250 ... 1600 A
Overload capability	$1,5 \cdot I_R$ for 3 min per hour or $2,5 \cdot I_R$ for 30 s per hour
Leakage current $I_{leak}$	at 250 Vac, 50 Hz
Climatic category	In accordance with IEC 68- 1 25/085/21 (– 25 °C/+ 85 °C/21 days damp heat test)

**Characteristics and ordering codes**

$I_R$ A	Terminal cross section mm <sup>2</sup>	$I_{leak}$ mA	$R_{typ}$ mΩ	Approx. weight kg	Ordering code
8	4	< 3,5	40	2,2	B84143- A8- R
12	4	< 3,5	20	2,2	B84143- A12- R
16	4	< 3,5	15	2,2	B84143- A16- R
25	10	< 3,5	8	3,7	B84143- A25- R
36	10	< 3,5	2,5	3,7	B84143- A36- R
50	10	< 6	2	4,0	B84143- A50- R
80	25	< 6	1	9,5	B84143- A80- R
120	50	< 6	0,75	10	B84143- A120- R
150	50	< 6	0,4	10	B84143- A150- R
180	95	< 6	0,4	13	B84143- A180- R
250	Terminal lugs	< 6	0,095	30	B84143- A250- S
500		< 6	0,060	49	B84143- A500- S
1000		< 6	0,030	90	B84143- A1000- S
1600		< 6	0,020	130	B84143- A1600- S

Dimensional drawings

B84143- A8- R ... B84143- A16- R

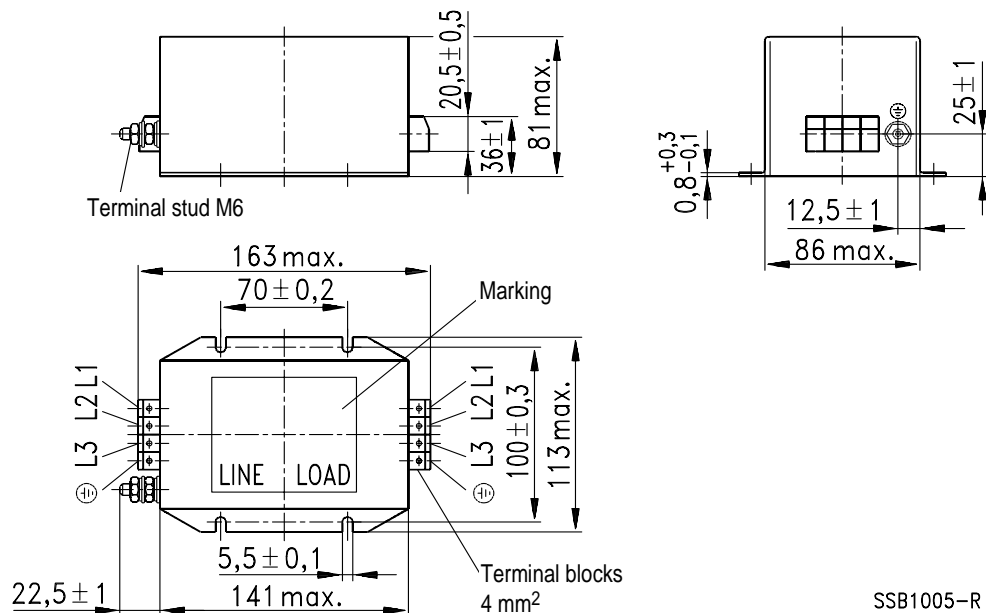

B84143- A25- R ... A50- R

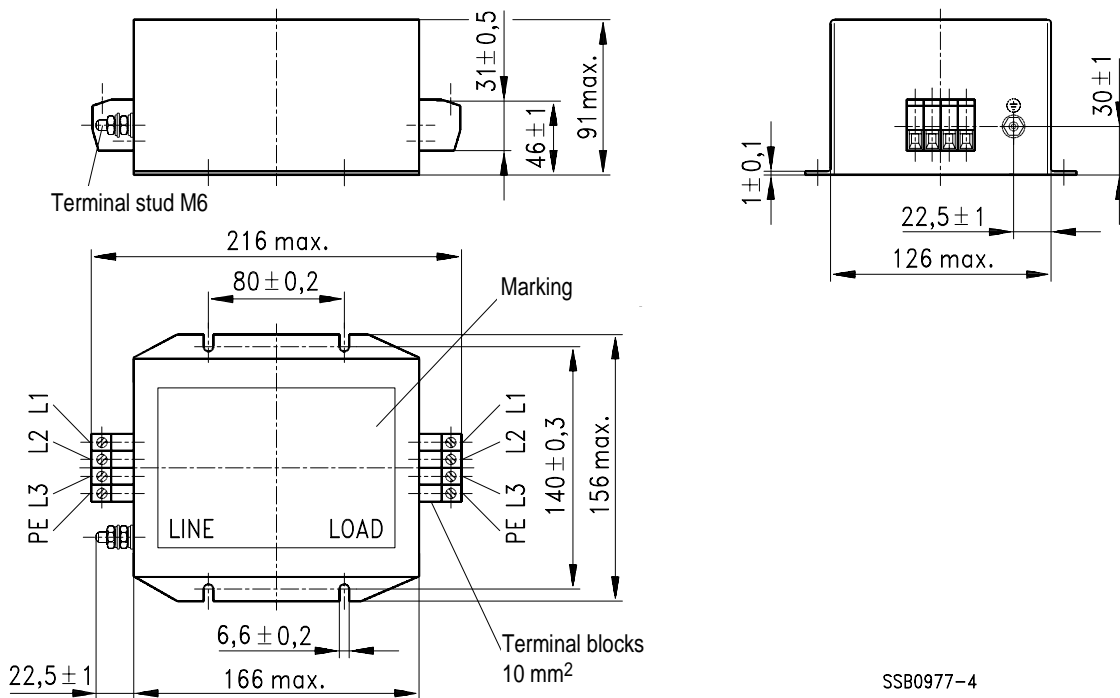

B84143- A80- R

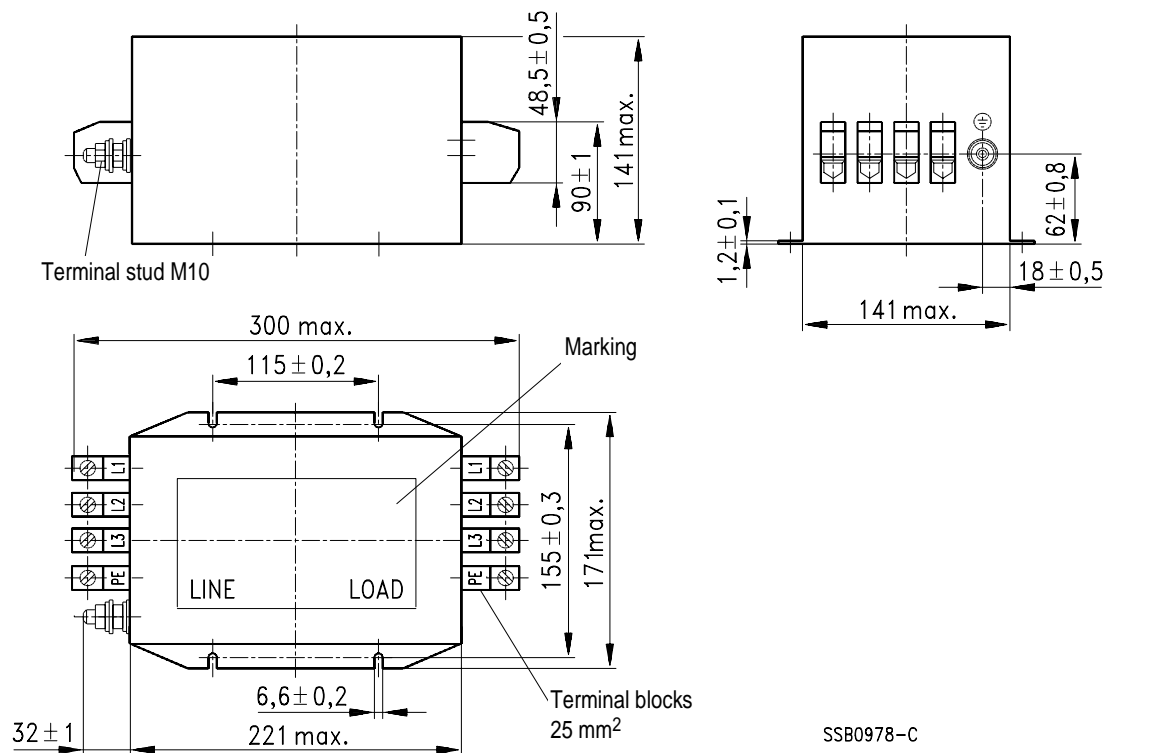

B84143- A120- R, B84143- A150- R

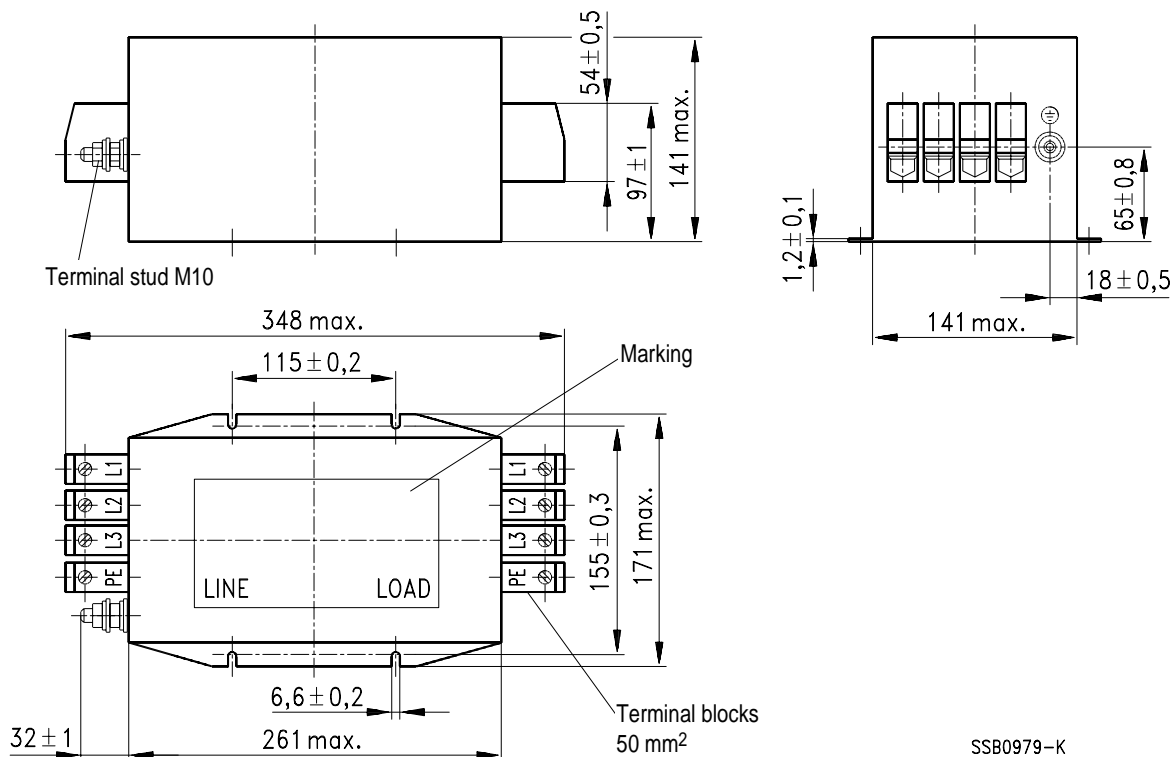

B84143- A180- R

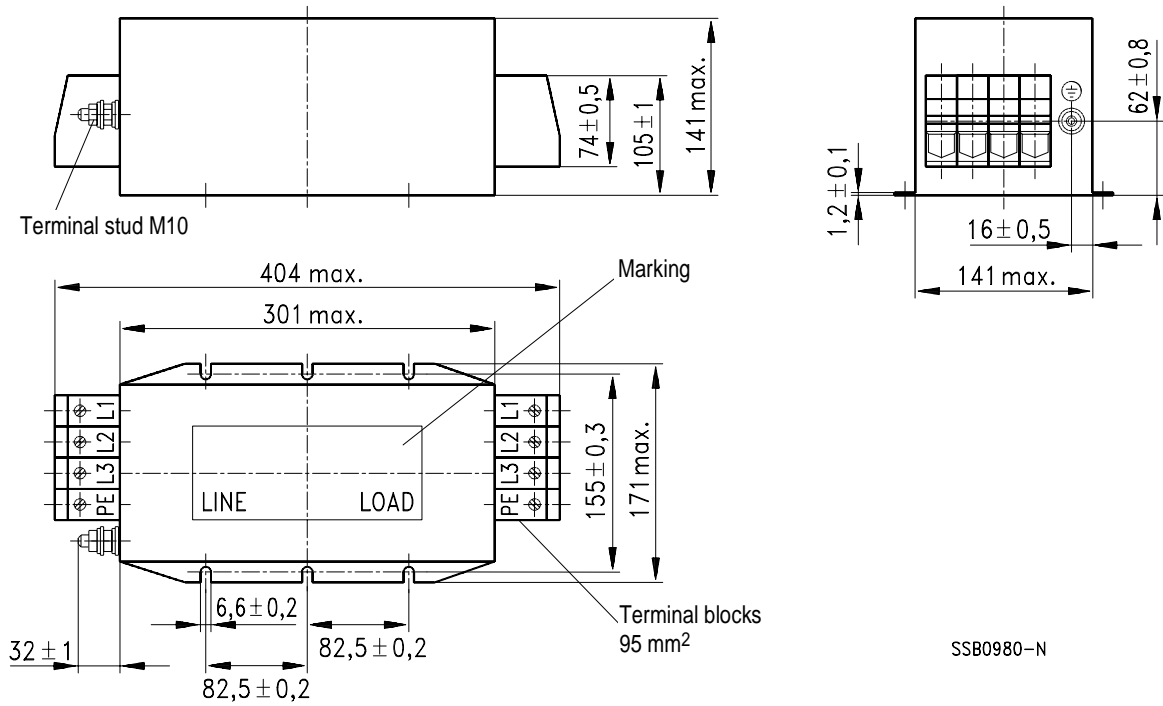

B84143- A250- S

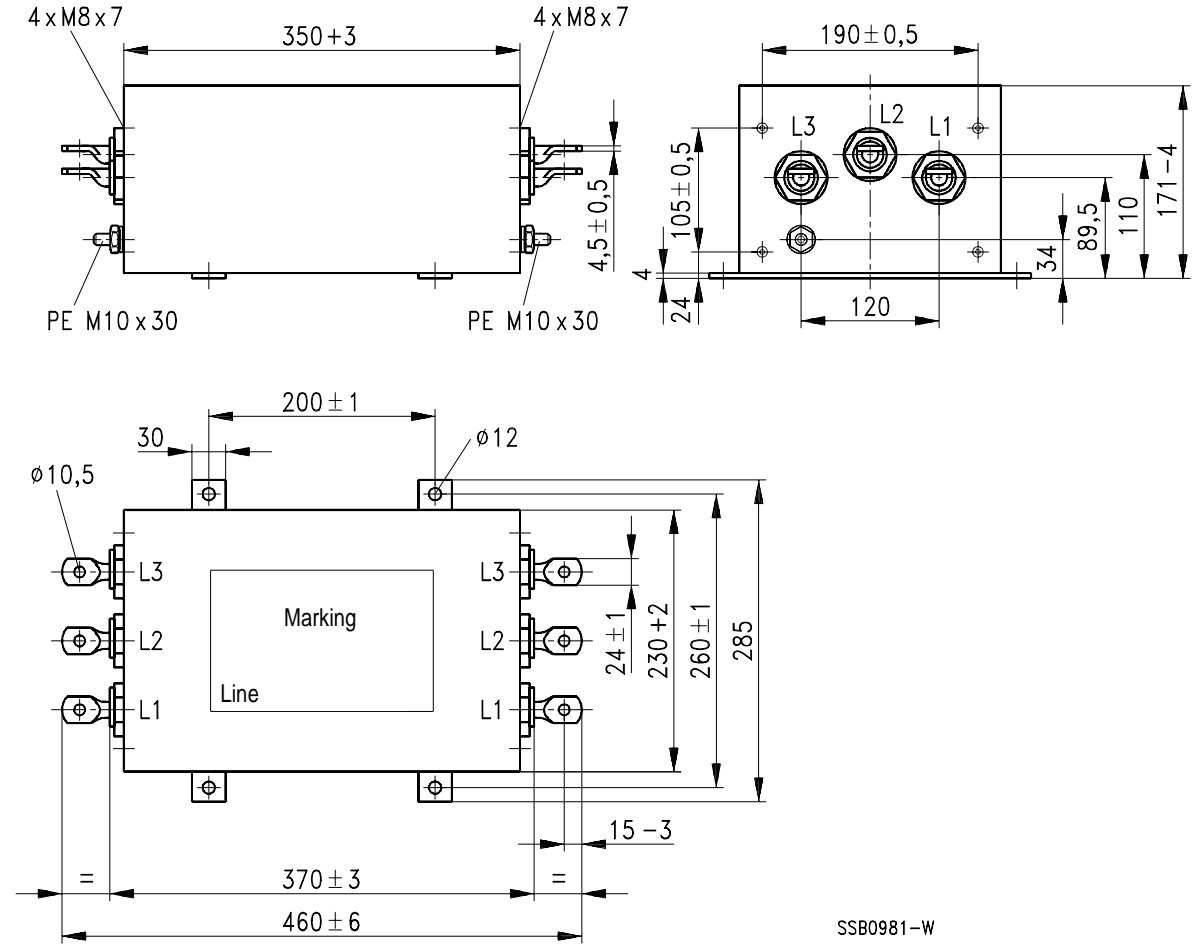

B84143- A500- S

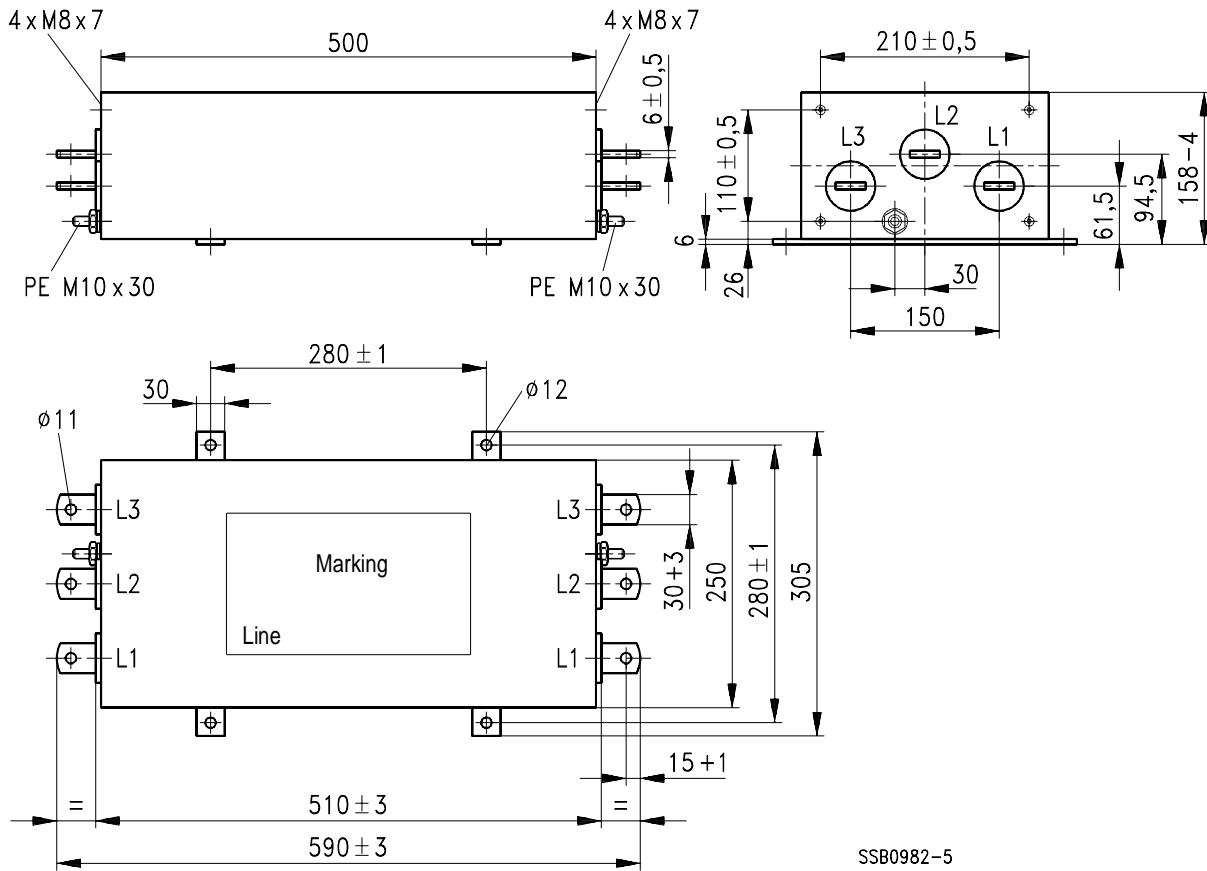

SSB0982-5

B84143- A1000- S

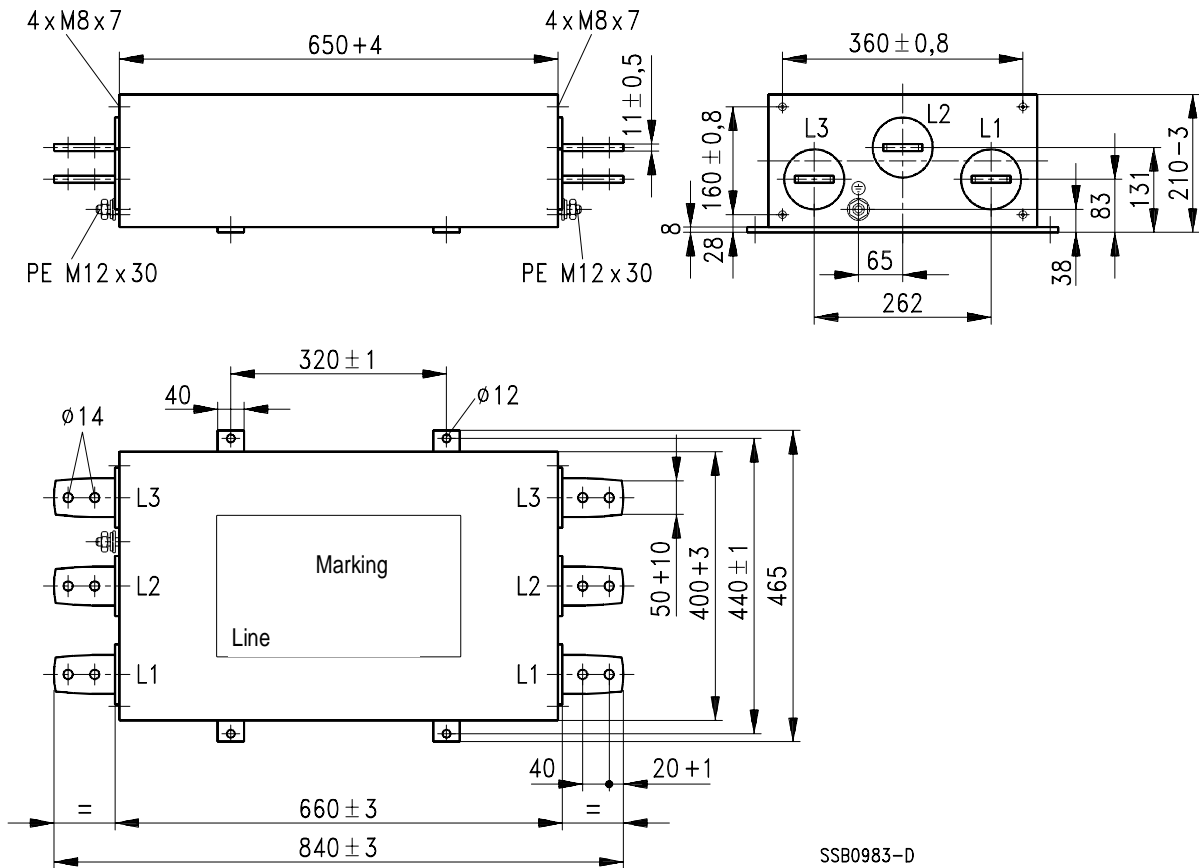

SSB0983-D



B84143- A1600- S

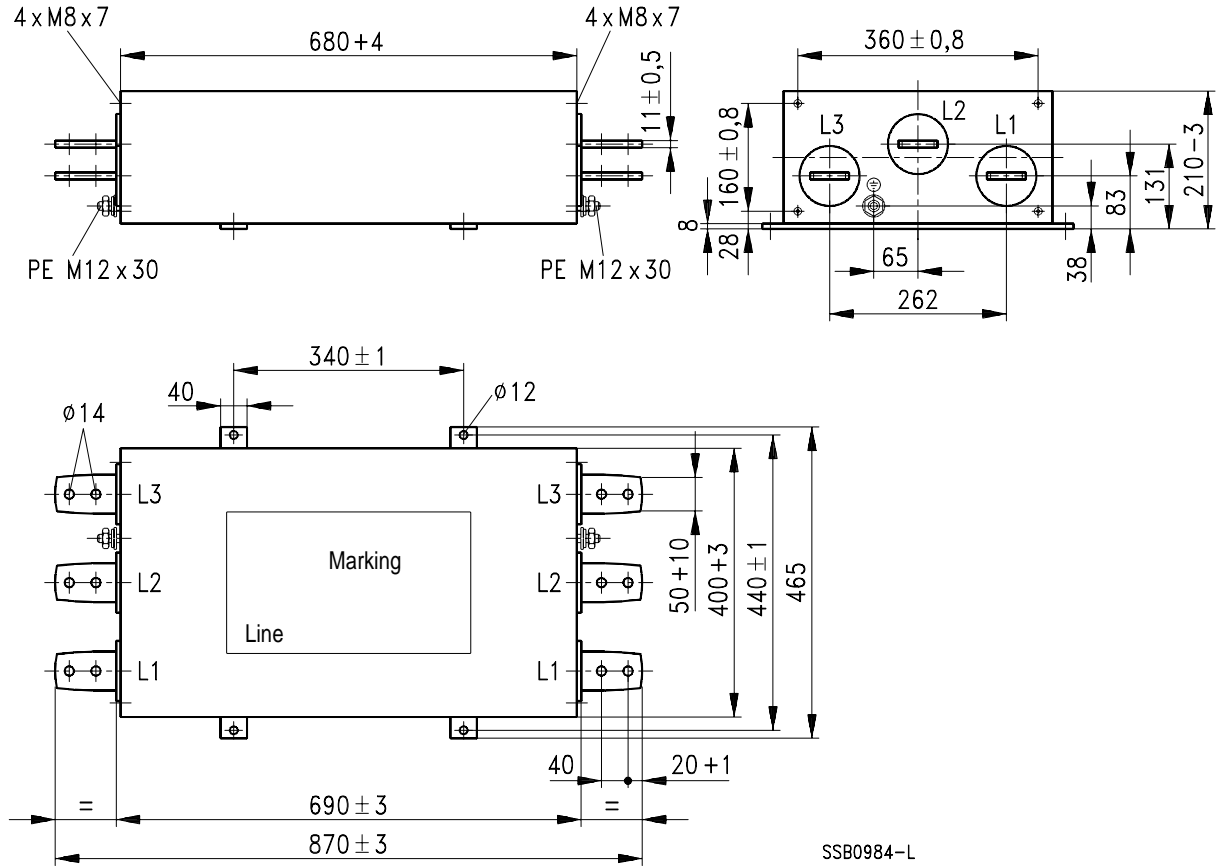

SSB0984-L

**Insertion loss** (typical values at  $Z = 50 \Omega$ )

- unsymmetrical, adjacent branches terminated
- ..... asymmetrical, all branches in parallel (common mode)
- - - - - symmetrical (differential mode)

B84143- A8- R

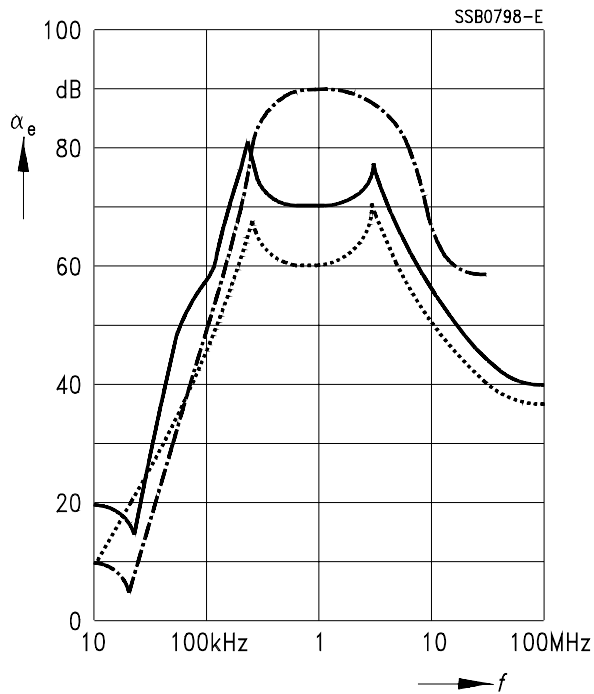

B84143- A12- R

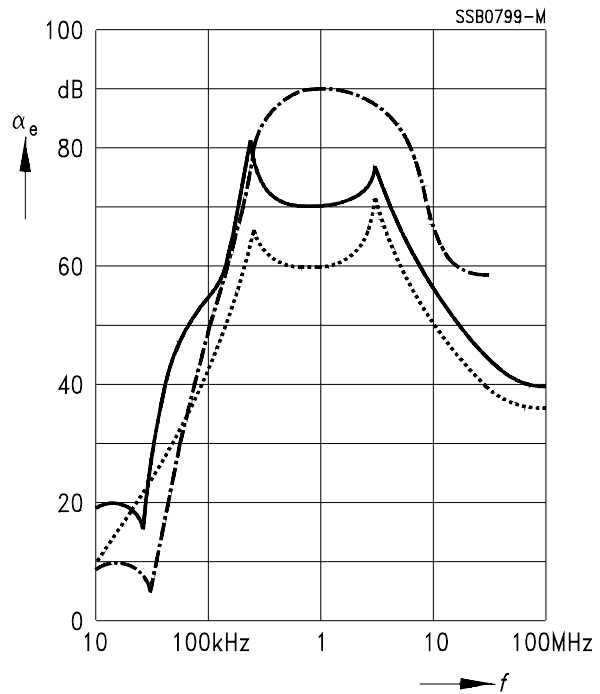

B84143- A16- R

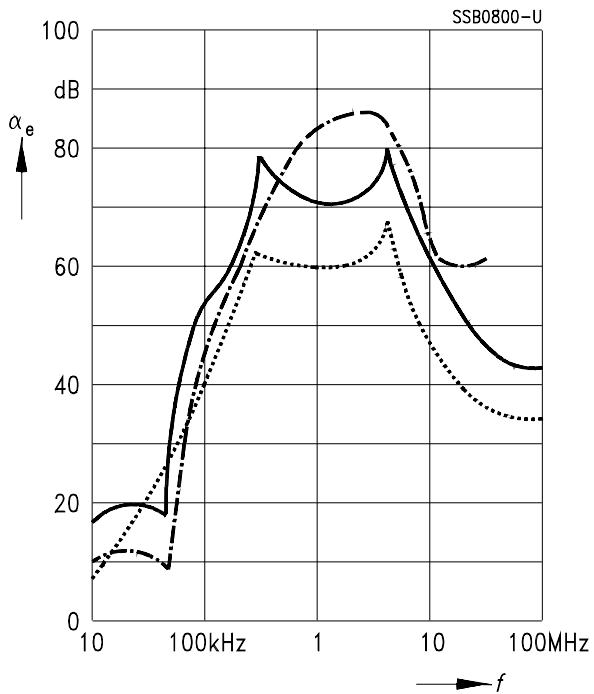

B84143- A25- R

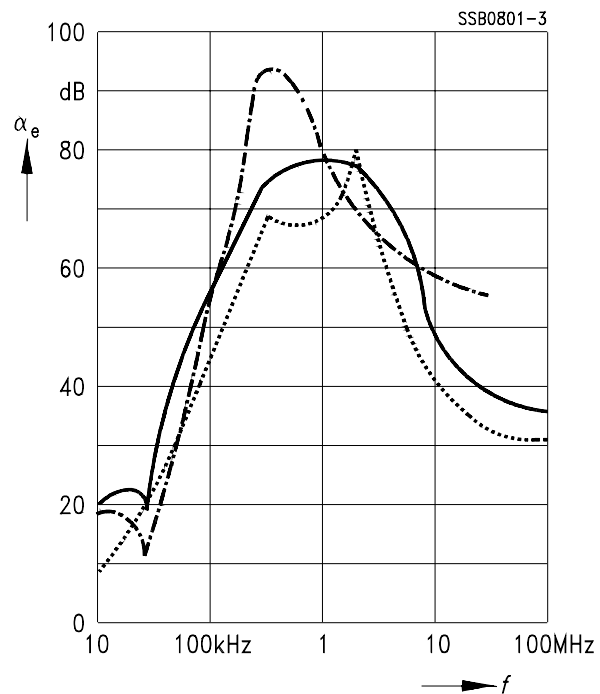

**Insertion loss** (typical values at  $Z = 50 \Omega$ )

- unsymmetrical, adjacent branches terminated
- ..... asymmetrical, all branches in parallel (common mode)
- - - - - symmetrical (differential mode)

B84143- A36- R

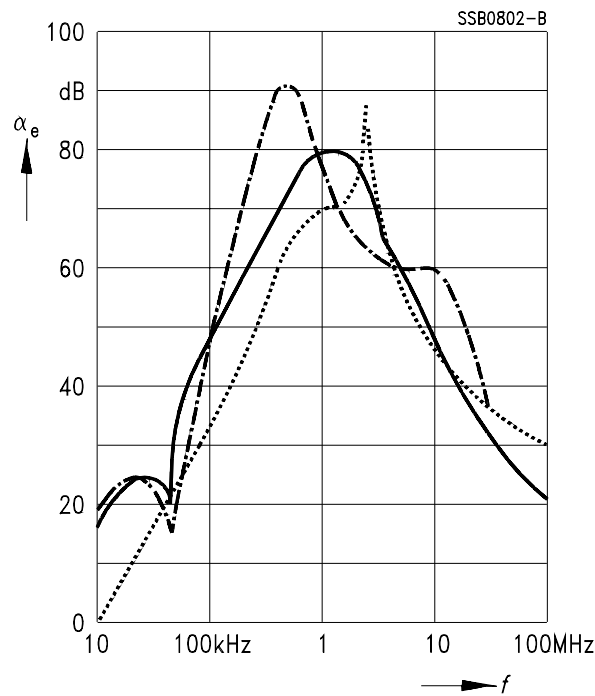

B84143- A50- R

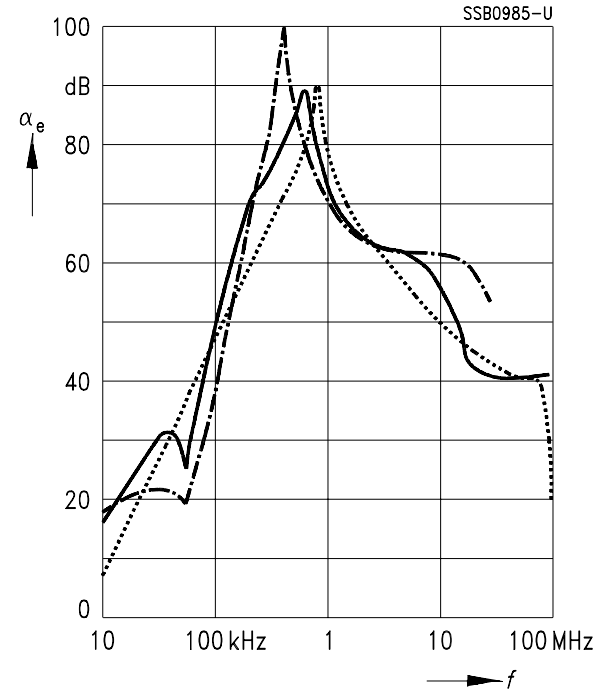

B84143- A80- R

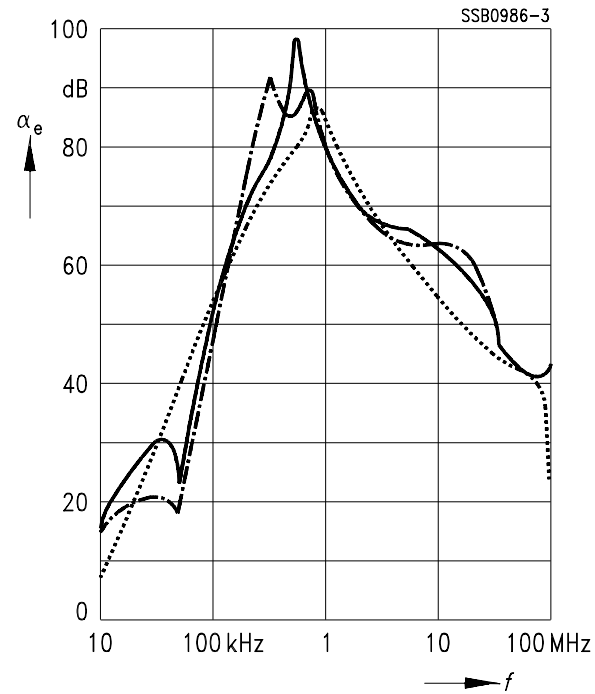

B84143- A120- R ... B84143- A180- R

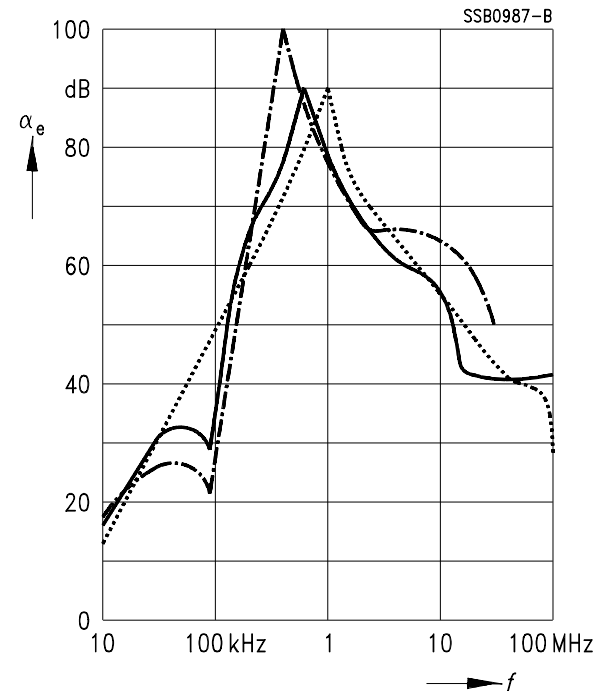

Insertion loss (typical values at Z = 50 Ω)

- unsymmetrical, adjacent branches terminated
- ..... asymmetrical, all branches in parallel (common mode)
- - - - - symmetrical (differential mode)

B84143- A250- S

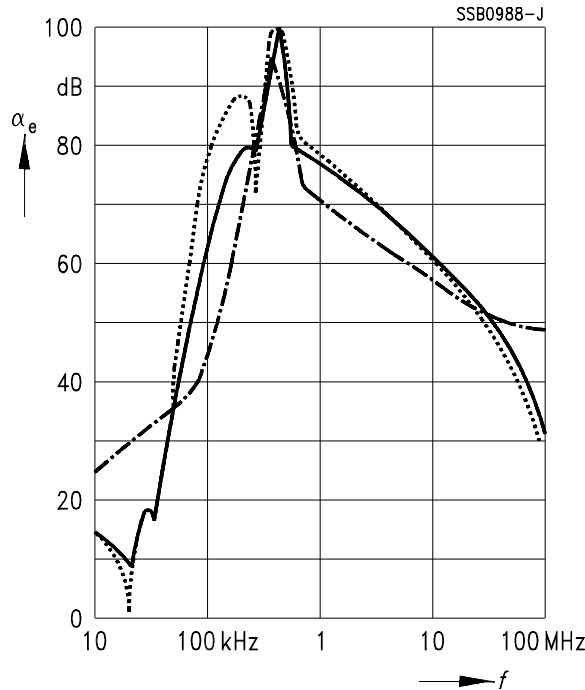

B84143- A500- S

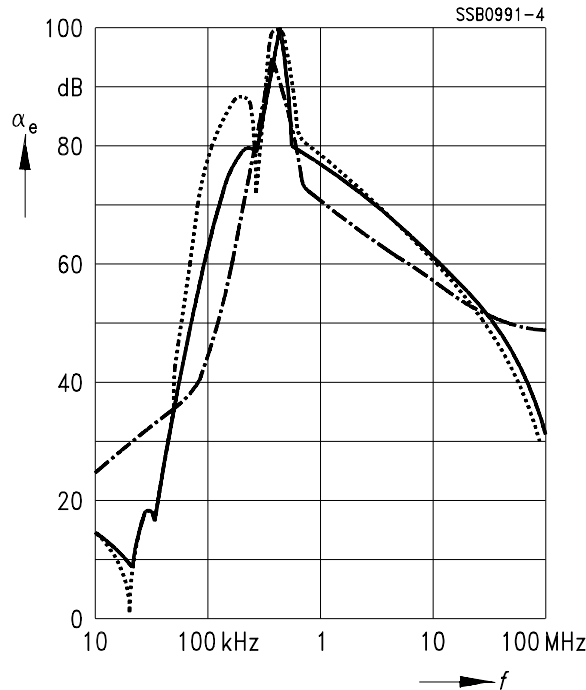

B84143- A1000- S

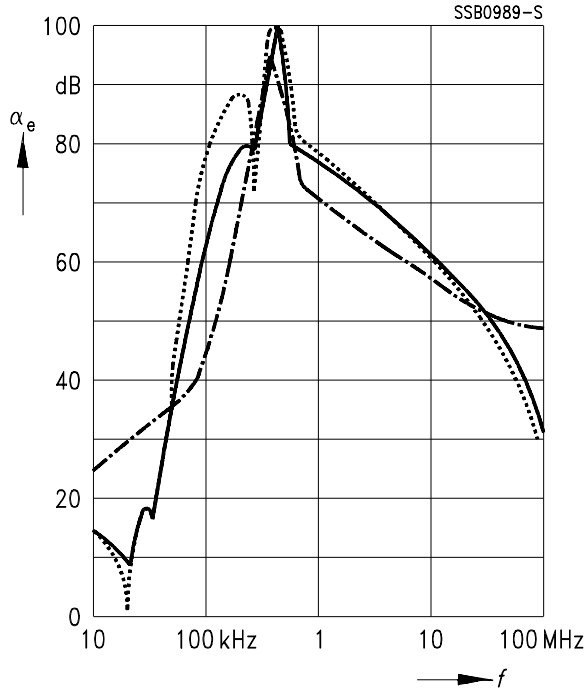

B84143- A1600- S

